

TB62755FPG

Step Up Type DC/DC Converter for White LED

The TB62755FPG is a high efficient Step-Up Type DC/DC Converter specially designed for constant current driving of White LED.

This IC can drive 2-8 white LEDs connected series using a Li-ion battery.

This IC contains N-ch MOS-FET Transistor for Coil-Switching, and LED current (IF) is set with an external resistor.

This IC is especially for driving back light white LEDs in LCD of PDA, Cellular Phone, or Handy Terminal Equipment.

This device is Pb-free product.

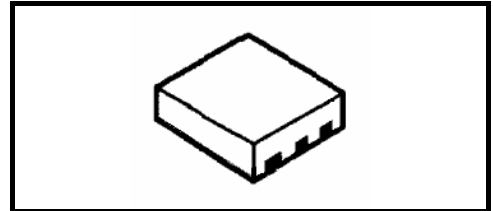

Weight: 0.005 g (typ.)

Features

- 2-8 white LEDs connected series (typ. 7LEDs)
- Variable LED current IF is set with a external resistor: 20 mA (typ.) @RSENS = 15 Ω
- Output power: Available for 800 mW LED loading (7LEDs, IF = Over 25 mA)
- High efficiency: 80% over (using recommended external parts)
- Output over voltage shutdown function
: Switching operation is shut downed when OVD terminal voltage is over 37 V (typ.).
- IC package: PLP-6
- Switching frequency: 1.0 MHz (typ.)

Pin Assignment (top view)

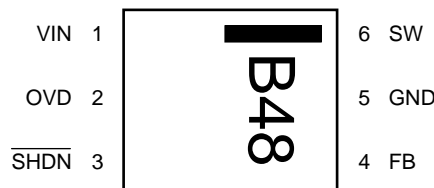

Note: This IC could be destroyed in some case if amounted in 180° inverse direction.
Please be careful about IC direction in mounting.

Block Diagram

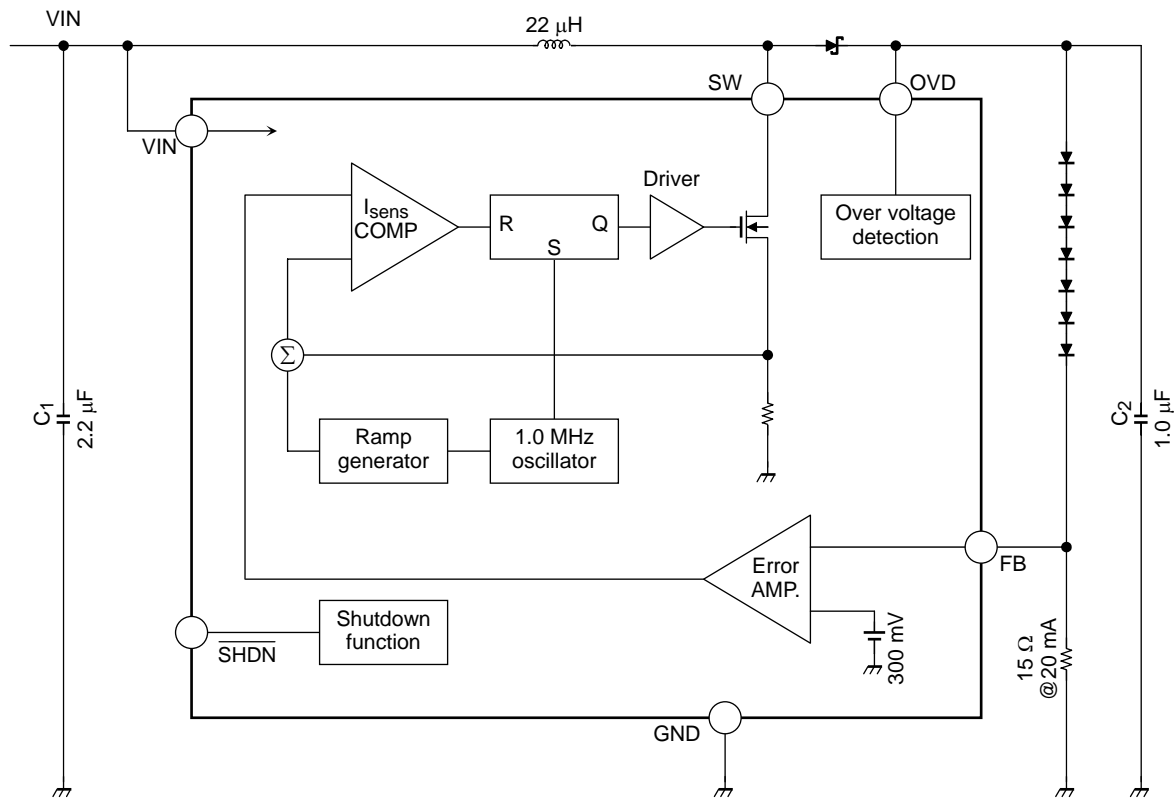

Pin Function

Pin No.	Symbol	Function Description
1	VIN	Supply voltage input terminal. (2.8 V to 5.5 V)
2	OVD	Over voltage detection terminal. IC switching operation is disabled with detection over voltage. If the voltage returns to detection level or less, operation is enabled again.
3	$\overline{\text{SHDN}}$	Voltage-input terminal for IC-enable/disable LED- I_F . A high input on this pin enables the IC to operate while a low input causes it to shut down. The behavior of the IC is unpredictable if the input on the pin is undefined. Ensure that the pin is tied to either a high or low level.
4	FB	LED I_F setting resistor connecting terminal.
5	GND	Ground terminal.
6	SW	Switch terminal for DC/DC converter. Nch MOSFET built-in.

Absolute Maximum Ratings (Ta = 25°C if without notice)

Characteristics	Symbol	Rating	Unit
Power supply voltage	VIN	-0.3 to +6.0	V
Input voltage	VIN ($\overline{\text{SHDN}}$)	-0.3 to +VIN + 0.3 (Note 1)	V
Switching terminal voltage	VO (SW)	-0.3 to +40	V
Switching terminal current	IO (SW)	1500	mA
Power dissipation	PD	TBD (device)	W
		TBD (on PCB) (Note 2)	
Thermal resistance	Rth (j-a)	TBD (device)	°C/W
		TBD (on PCB)	
Operation temperature range	Topr	-40 to +85	°C
Storage temperature range	Tstg	-55 to +150	°C
Maximum junction temperature	Tj	150	°C

Note 1: Ensure that the supply voltage never exceeds 6.0 V.

Note 2: Power dissipation must be calculated with subtraction of TBD mW/°C from maximum rating with every 1°C if Topr is upper 25°C. (on PCB)

Recommended Operating Condition (Ta = -40 to 85°C if without notice)

Characteristics	Symbol	Test Circuit	Test Condition	Min	Typ.	Max	Unit
Power supply voltage	VIN	—		2.8	—	5.5	V
LED current	IF	—	VIN = 3.6 V, RSENS = 15 Ω 7 white LEDs, Ta = 25°C	—	20	—	mA

Electrical Characteristics (Ta = 25°C, VIN = 2.8 to 5.5 V if without notice)

Characteristics	Symbol	Test Circuit	Test Condition	Min	Typ.	Max	Unit
Power supply voltage	VIN	—		2.8	—	5.5	V
Operating consumption current	IIN (ON)	1	VIN = 3.6 V, RSENS = 15 Ω	—	0.6	0.9	mA
Quiescent consumption current	IIN (OFF)	2	VIN = 3.6 V, $\overline{\text{SHDN}} = 0$ V	—	0.5	1.0	μA
$\overline{\text{SHDN}}$ terminal "H" level input voltage	V $\overline{\text{SHDNH}}$	3	—	1.3	—	VIN	V
$\overline{\text{SHDN}}$ terminal "L" level input voltage	V $\overline{\text{SHDNL}}$	3	—	0	—	0.4	V
$\overline{\text{SHDN}}$ terminal current	I $\overline{\text{SHDN}}$	4	VIN = 3.6 V, $\overline{\text{SHDN}} = 3.6$ V or 0 V	—	0	1.0	μA
Integrated MOS-Tr switching frequency	fOSC	5	VIN = 3.6 V, $\overline{\text{SHDN}} = 3.6$ V	0.77	1.0	1.43	MHz
Switching terminal leak current	Ioz (SW)	6	—	—	0.5	1	μA
FB terminal feedback voltage	VFB	7	VIN = 3.6 V, RSENS = 15 Ω Ta = 25°C, L = 22 μH	285	300	315	mV
		7	VIN = 4.2 V, RSENS = 150 Ω Ta = 25°C, L = 22 μH	285	300	315	mV
FB terminal line regulation	ΔVFB	7	VIN = 3.6 V (typ.) VIN = 3.0 to 5.0 V	-5	—	5	%
FB terminal current	IFB	8	VIN = 3.6 V, $\overline{\text{SHDN}} = 3.6$ V, VFB = 300 mV	—	0.02	—	μA
OVD terminal detect voltage	VOVD	9	—	34.5	37	39.5	V
OVD terminal leakage current	IOVD	10	VOVD = 30 V	—	0.5	1	μA

Usage Precautions

Protection in LED Opened Condition

The operation with OVD terminal is available for the protection in case LED circuit opened.

When the voltage of OVD terminal is over 37 V (typ.), Nch MOS switching operation is disabled in the IC. When the voltage of OVD terminal drops below 37 V (typ.), Nch MOS switching operation becomes available again.

If load of LED is detached, Nch MOS switching operation is disabled with detection of boost circuit voltage and the IC is protected from unexpected over voltage.

Setting of Capacitor

The recommended values are

$$C_1 = 2.2 \text{ } (\mu\text{F}) \text{ or more, } C_2 = 1.0 \text{ } (\mu\text{F}) \text{ or more}$$

The capacitor of ceramic condenser tends to decrease when voltage is applied.

So, please select the appropriate capacitor in consideration of IC characteristics of withstand voltage and size.

Setting of I_F

Resistance connects between RSENS pin and GND.

The average current is set by this RSENS value and average current are obtained by the following equation.

$$I_F \text{ (mA)} = \frac{300 \text{ [mV]}}{\text{RSENS} [\Omega]}$$

Current value error is within $\pm 5\%$.

Setting of External Inductor Size

Please select the inductor size with referring this table corresponding to each number of LEDs.

[Recommended inductor values]

LEDs	Indictor Size	Note
2 to 5	10 μH	LED current $I_F = 20 \text{ mA}$
Over 6	22 μH	

Current Dimming Control

Recommended brightness control circuits are 4 types.

- (1) Input PWM signal to $\overline{\text{SHDN}}$ terminal
 I_F can be adjusted with PWM signal by inputting it to $\overline{\text{SHDN}}$ terminal.

<<PWM signal frequency>>

- The recommended PWM signal frequency is from 100 Hz to 10 kHz. There is a possibility to arise the audible frequency in mounting to the board because it is within the auditory area. The greater the oscillation frequency is, the greater the error between the actual value and the theoretical value becomes.

<<Constant number of external condenser>>

- When the PWM signal is off, the time to drain C_2 of charge depends on the constant number. And so, the actual value is little different from the theoretical value.

<<PWM input signal>>

- Set the amplitude of PWM signal within the range of $\overline{\text{SHDN}}$ terminal specification.

<<Rush current in inputting>>

- In case dimming by inputting the PWM signal to the $\overline{\text{SHDN}}$ terminal, this IC turns on and off repeatedly.
 And the rush current, which provides the charge to C_2 , arises in turning on. Take care in selecting the condenser.

<<Current value in control with PWM: Ideal equation>>

$$I_F [\text{mA}] = \frac{300 [\text{mV}] \times \text{ON Duty} [\%]}{R_{\text{SENS}} [\Omega]}$$

<<Recommended application>>

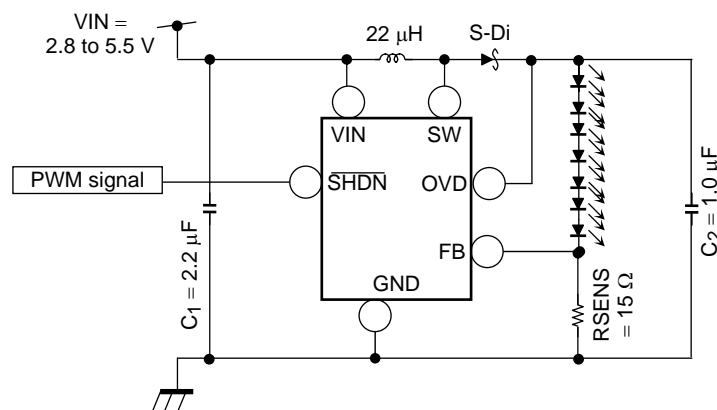

- (2) Input analog voltage to FB terminal
 I_F can be adjusted with analog voltage input to FB terminal.
 This method is without repeating IC ON/OFF, and no need to consider holding rash current.

[Notice]

- LED current value goes over 100% of the current set with RSENS, if the input analog voltage is between 0 V to 300 mV (typ.).

<<Recommended application>>

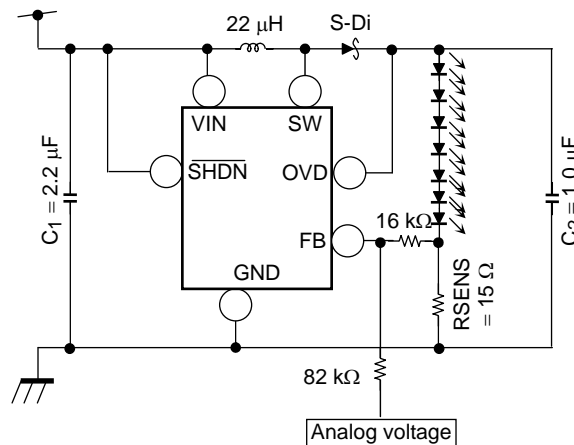

- (3) Input PWM signal with filtering to FB terminal
 I_F can be adjusted with filtering PWM signal using RC filter indicated in recommended circuit, because the PWM signal can be regard as analog voltage after filtering.
 This method is without repeating IC ON/OFF, and no need to consider holding rash current.

[Notice]

- LED current value goes over 100% of the current set with RSENS, if the input voltage after filtering is between 0 V to 300 mV (typ.).

<<Recommended application>>

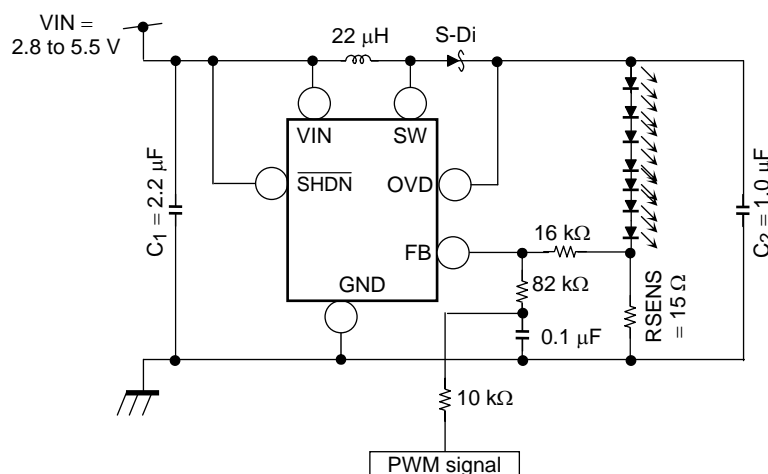

(4) Input logic signal

I_F can be adjusted with logic signal input as indicated in recommended circuit.
The resistor connected the ON-State Nch MOS drain and RSENS determines I_F.

Average of setting current I_O (mA) is next, approximately.

$$I_F \text{ [mA]} = \frac{300 \text{ [mV]}}{\text{Sum of resistor value } [\Omega]}$$

<<Recommended application>>

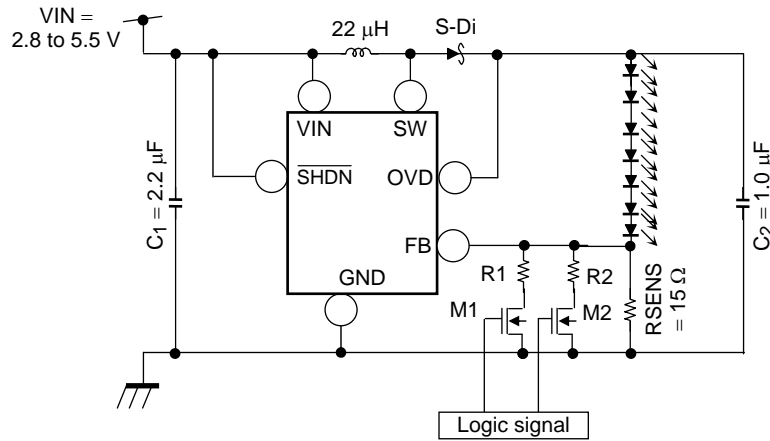

M1	M2	LED Current
OFF	OFF	$\frac{300 \text{ [mV]}}{R_{SENS} [\Omega]}$
ON	OFF	$300 \text{ [mV]} \times \frac{R_{SENS} [\Omega] + R1 [\Omega]}{R_{SENS} [\Omega] \times R1 [\Omega]}$
OFF	ON	$300 \text{ [mV]} \times \frac{R_{SENS} [\Omega] + R2 [\Omega]}{R_{SENS} [\Omega] \times R2 [\Omega]}$
ON	ON	$300 \text{ [mV]} \times \frac{R_{SENS} [\Omega] \times R1 [\Omega] + R_{SENS} [\Omega] \times R2 [\Omega] + R1 [\Omega] \times R2 [\Omega]}{R_{SENS} [\Omega] \times R1 [\Omega] \times R2 [\Omega]}$

TEST Circuit

1. I_{IN} (ON)

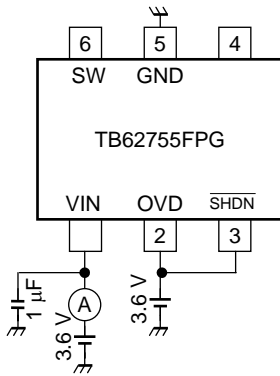

2. I_{IN} (OFF)

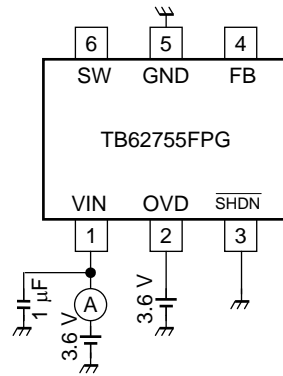

3. V_{SHDNH} , V_{SHDNL}

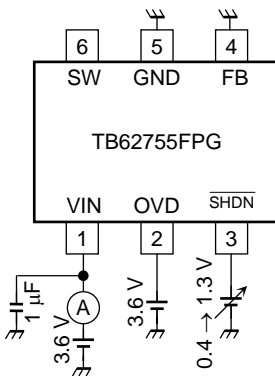

4. I_{SHDN}

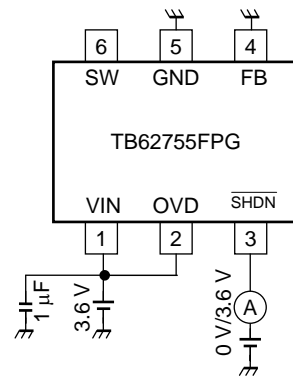

5. f_{osc}

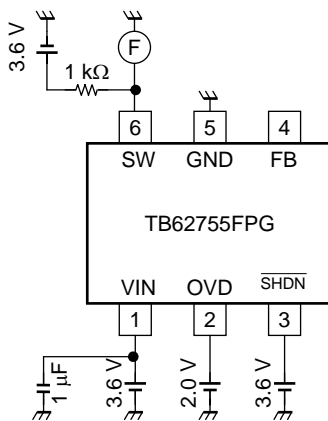

6. I_{oz} (SW)

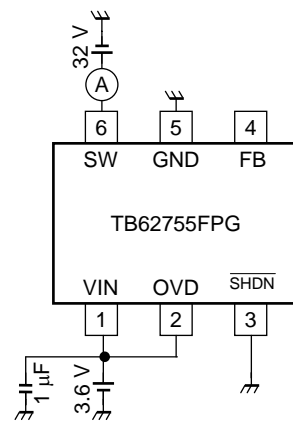

7. $V_{FB}, \Delta V_{FB}^{*1}$

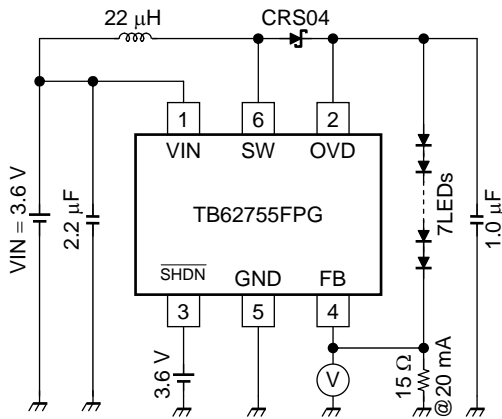

8. I_{FB}

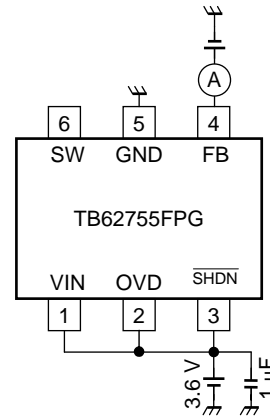

9. V_{OVD}^{*1}

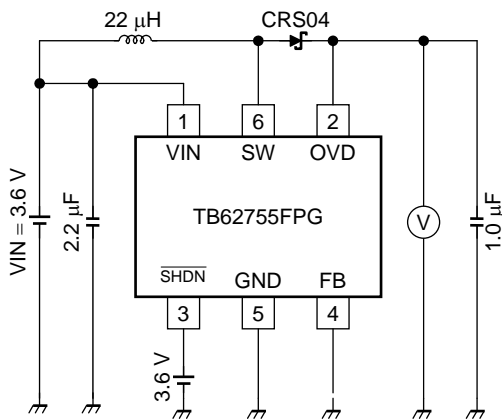

10. I_{OVD}

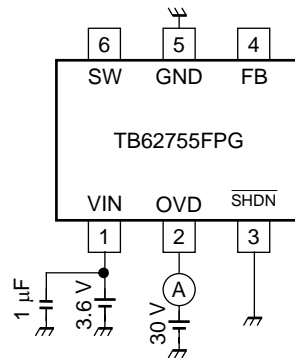

*1: The locations of the pins differ from the actual ones to simplify the diagram. See page 1 for the actual pin locations.

Package Dimensions

SON6-P-0202-0.50 Rev01

Unit : mm

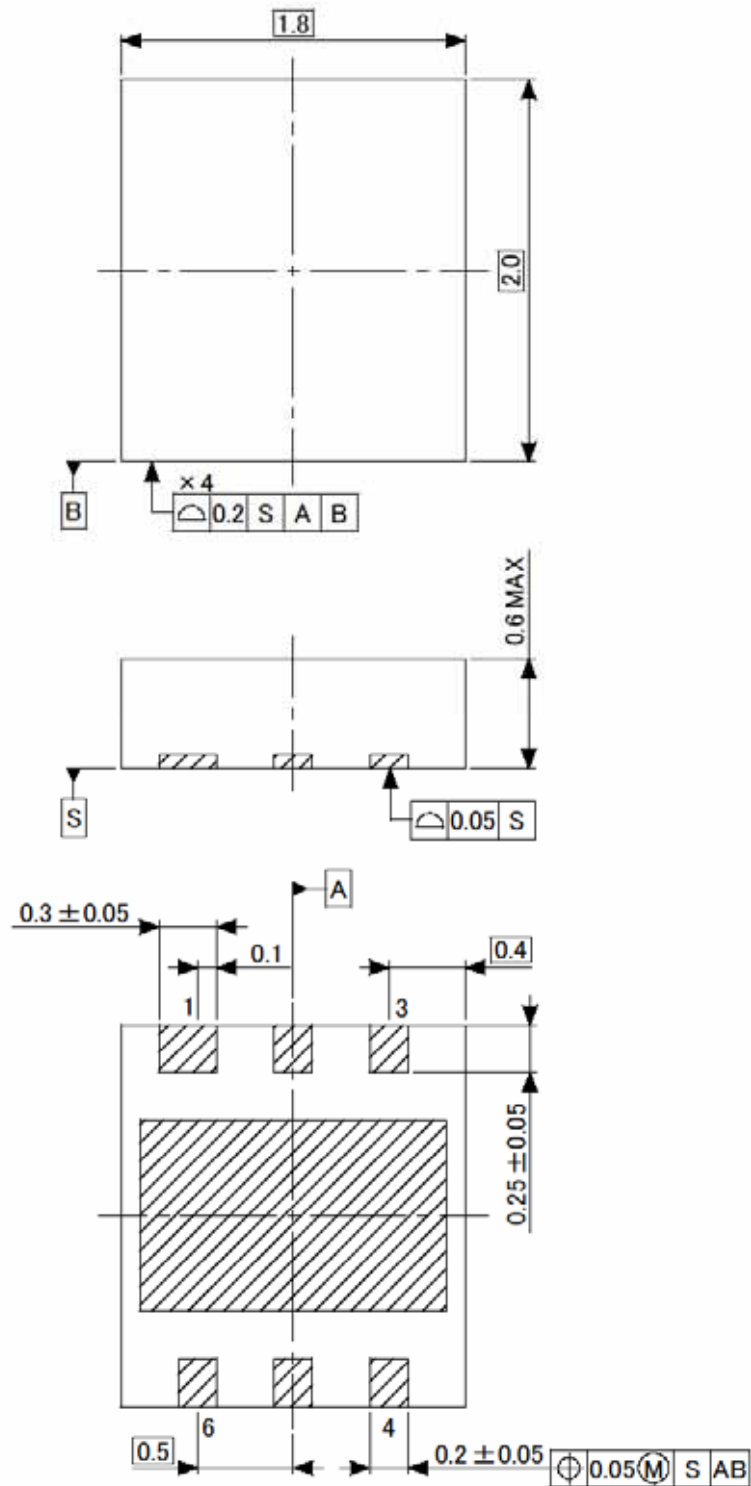

Weight: 0.005g (typ.)

Notes on Contents

1. Block Diagrams

Some of the functional blocks, circuits, or constants in the block diagram may be omitted or simplified for explanatory purposes.

2. Equivalent Circuits

The equivalent circuit diagrams may be simplified or some parts of them may be omitted for explanatory purposes.

3. Timing Charts

Timing charts may be simplified for explanatory purposes.

4. Application Circuits

The application circuits shown in this document are provided for reference purposes only. Thorough evaluation is required, especially at the mass production design stage.

Toshiba does not grant any license to any industrial property rights by providing these examples of application circuits.

5. Test Circuits

Components in the test circuits are used only to obtain and confirm the device characteristics. These components and circuits are not guaranteed to prevent malfunction or failure from occurring in the application equipment.

IC Usage Considerations

Notes on Handling of ICs

- (1) The absolute maximum ratings of a semiconductor device are a set of ratings that must not be exceeded, even for a moment. Do not exceed any of these ratings.
Exceeding the rating(s) may cause the device breakdown, damage or deterioration, and may result injury by explosion or combustion.
- (2) Use an appropriate power supply fuse to ensure that a large current does not continuously flow in case of over current and/or IC failure. The IC will fully break down when used under conditions that exceed its absolute maximum ratings, when the wiring is routed improperly or when an abnormal pulse noise occurs from the wiring or load, causing a large current to continuously flow and the breakdown can lead smoke or ignition. To minimize the effects of the flow of a large current in case of breakdown, appropriate settings, such as fuse capacity, fusing time and insertion circuit location, are required.
- (3) If your design includes an inductive load such as a motor coil, incorporate a protection circuit into the design to prevent device malfunction or breakdown caused by the current resulting from the inrush current at power ON or the negative current resulting from the back electromotive force at power OFF. IC breakdown may cause injury, smoke or ignition.
Use a stable power supply with ICs with built-in protection functions. If the power supply is unstable, the protection function may not operate, causing IC breakdown. IC breakdown may cause injury, smoke or ignition.
- (4) Do not insert devices in the wrong orientation or incorrectly.
Make sure that the positive and negative terminals of power supplies are connected properly. Otherwise, the current or power consumption may exceed the absolute maximum rating, and exceeding the rating(s) may cause the device breakdown, damage or deterioration, and may result injury by explosion or combustion.
In addition, do not use any device that is applied the current with inserting in the wrong orientation or incorrectly even just one time.

- (5) Carefully select external components (such as inputs and negative feedback capacitors) and load components (such as speakers), for example, power amp and regulator.
If there is a large amount of leakage current such as input or negative feedback condenser, the IC output DC voltage will increase. If this output voltage is connected to a speaker with low input withstand voltage, overcurrent or IC failure can cause smoke or ignition. (The over current can cause smoke or ignition from the IC itself.) In particular, please pay attention when using a Bridge Tied Load (BTL) connection type IC that inputs output DC voltage to a speaker directly.

Points to remember on handling of ICs

- (1) **Thermal Shutdown Circuit**
Thermal shutdown circuits do not necessarily protect ICs under all circumstances. If the thermal shutdown circuits operate against the over temperature, clear the heat generation status immediately. Depending on the method of use and usage conditions, such as exceeding absolute maximum ratings can cause the thermal shutdown circuit to not operate properly or IC breakdown before operation.
- (2) **Heat Radiation Design**
In using an IC with large current flow such as power amp, regulator or driver, please design the device so that heat is appropriately radiated, not to exceed the specified junction temperature (T_j) at any time and condition. These ICs generate heat even during normal use. An inadequate IC heat radiation design can lead to decrease in IC life, deterioration of IC characteristics or IC breakdown. In addition, please design the device taking into consideration the effect of IC heat radiation with peripheral components.
- (3) **Back-EMF**
When a motor rotates in the reverse direction, stops or slows down abruptly, a current flow back to the motor's power supply due to the effect of back-EMF. If the current sink capability of the power supply is small, the device's motor power supply and output pins might be exposed to conditions beyond maximum ratings. To avoid this problem, take the effect of back-EMF into consideration in system design.

About solderability, following conditions were confirmed

- Solderability
 - (1) Use of Sn-37Pb solder Bath
 - solder bath temperature = 230°C
 - dipping time = 5 seconds
 - the number of times = once
 - use of R-type flux
 - (2) Use of Sn-3.0Ag-0.5Cu solder Bath
 - solder bath temperature = 245°C
 - dipping time = 5 seconds
 - the number of times = once
 - use of R-type flux

RESTRICTIONS ON PRODUCT USE

060925EBA

- The information contained herein is subject to change without notice. 021023_D
- TOSHIBA is continually working to improve the quality and reliability of its products. Nevertheless, semiconductor devices in general can malfunction or fail due to their inherent electrical sensitivity and vulnerability to physical stress. It is the responsibility of the buyer, when utilizing TOSHIBA products, to comply with the standards of safety in making a safe design for the entire system, and to avoid situations in which a malfunction or failure of such TOSHIBA products could cause loss of human life, bodily injury or damage to property.
In developing your designs, please ensure that TOSHIBA products are used within specified operating ranges as set forth in the most recent TOSHIBA products specifications. Also, please keep in mind the precautions and conditions set forth in the "Handling Guide for Semiconductor Devices," or "TOSHIBA Semiconductor Reliability Handbook" etc. 021023_A
- The TOSHIBA products listed in this document are intended for usage in general electronics applications (computer, personal equipment, office equipment, measuring equipment, industrial robotics, domestic appliances, etc.). These TOSHIBA products are neither intended nor warranted for usage in equipment that requires extraordinarily high quality and/or reliability or a malfunction or failure of which may cause loss of human life or bodily injury ("Unintended Usage"). Unintended Usage include atomic energy control instruments, airplane or spaceship instruments, transportation instruments, traffic signal instruments, combustion control instruments, medical instruments, all types of safety devices, etc. Unintended Usage of TOSHIBA products listed in this document shall be made at the customer's own risk. 021023_B
- The products described in this document shall not be used or embedded to any downstream products of which manufacture, use and/or sale are prohibited under any applicable laws and regulations. 060106_Q
- The information contained herein is presented only as a guide for the applications of our products. No responsibility is assumed by TOSHIBA for any infringements of patents or other rights of the third parties which may result from its use. No license is granted by implication or otherwise under any patent or patent rights of TOSHIBA or others. 021023_C
- The products described in this document are subject to foreign exchange and foreign trade control laws. 060925_E